

DK⁵⁰



Sistemi per l'abbattimento di polveri e odori
Dust and odour suppression systems



LUXTOWER 
www.luxtower.com



Sistemi per l'abbattimento di polveri e odori Dust and odour suppression systems

CARATTERISTICHE

- ▷ Ideale per demolizioni
- ▷ Ruote per facile spostamento
- ▷ Gancio traino
- ▷ Sistema di sollevamento tramite muletto
- ▷ Utilizzabile con radiocomando
- ▷ Ugelli intercambiabili per ottimizzazione della portata acqua
- ▷ Rotazione elettrica ed elettrovalvola acqua

FEATURES

- ▷ Ideal for small demolition
- ▷ Wheels for easy movement
- ▷ Tow hitch
- ▷ Lifting system by forklift
- ▷ For use with remote control
- ▷ Interchangeable nozzles for optimizing water flow
- ▷ Electric rotation and solenoid valve water

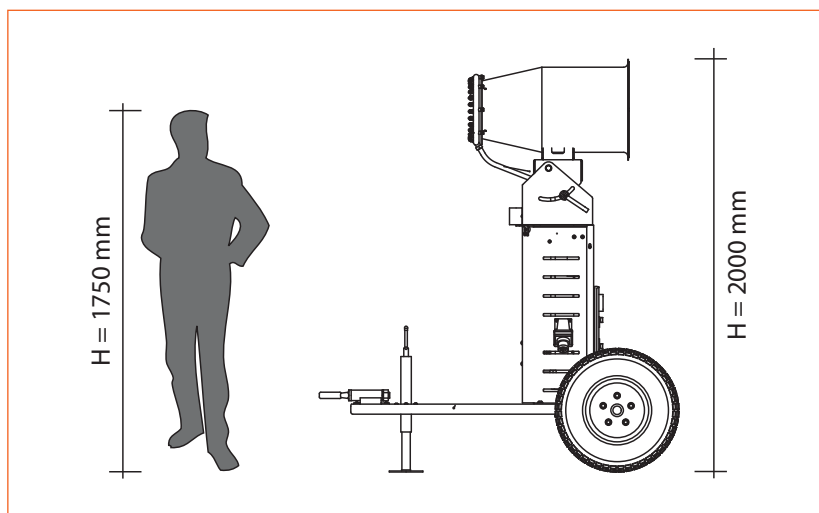

Consumo acqua con ugelli da 10GPH Water consumption with 10 gph nozzles

BAR	6	9	12	15
L./min	20	24	28	31

Dati tecnici	Technical data	DK 50
Potenza installata	Installed power	8 Kw
Potenza ventilatore	Fan power	5,5 Kw
Potenza pompa acqua	Water pump power	2,2 Kw
Grado di protezione	Protection rating	IP55
Alimentazione	Power supply	32A 3P+(N)+T 400Volts 50Hz
Alzo	Pitching	-20° +45°
Distanza max del getto	Max throw distance	40 m
Rumorosità	Noise level	< 93 Lwa
Peso a secco	Dry weight	240 Kg
Dimensioni (mm)	Dimensions (mm)	L = 1800 H = 2000 W = 1500
Pressione minima	Minimum pressure	1 Bar

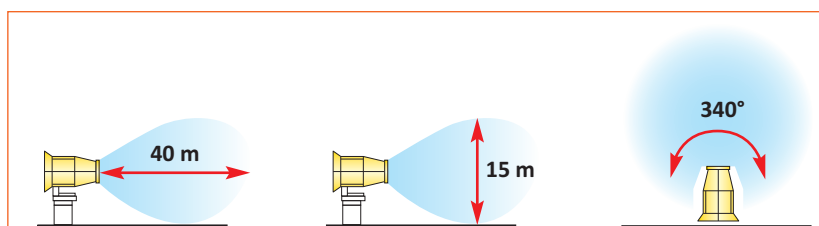

I dati sono indicativi e non vincolanti. Luxtower si riserva il diritto di apportare modifiche in qualsiasi momento e senza preavviso.
The data are indicative and not binding. Luxtower reserves the right to modify them at any time without prior notice.