

LE VERSIONI



RIA	RI	AC	HI	HIAC

DIMENSIONI

	mm	in		mm	in		mm	in		mm	in		mm	in	
(A)	1677	66	(D)	115	4.5	(G)	1528	60.2	(L)	768	30.2	(O)	1675	65.9	
(B)	755	29.7	(E)	695	27.4	(H)	1135	44.7	(M)	722	28.4	(P)	2010	79.1	
(C)	1155	45.5	(F)	2229	87.7	(I)	740	29.1	(N)	1677	66	(Q)	2765	108.9	
													(R)	695	27.4

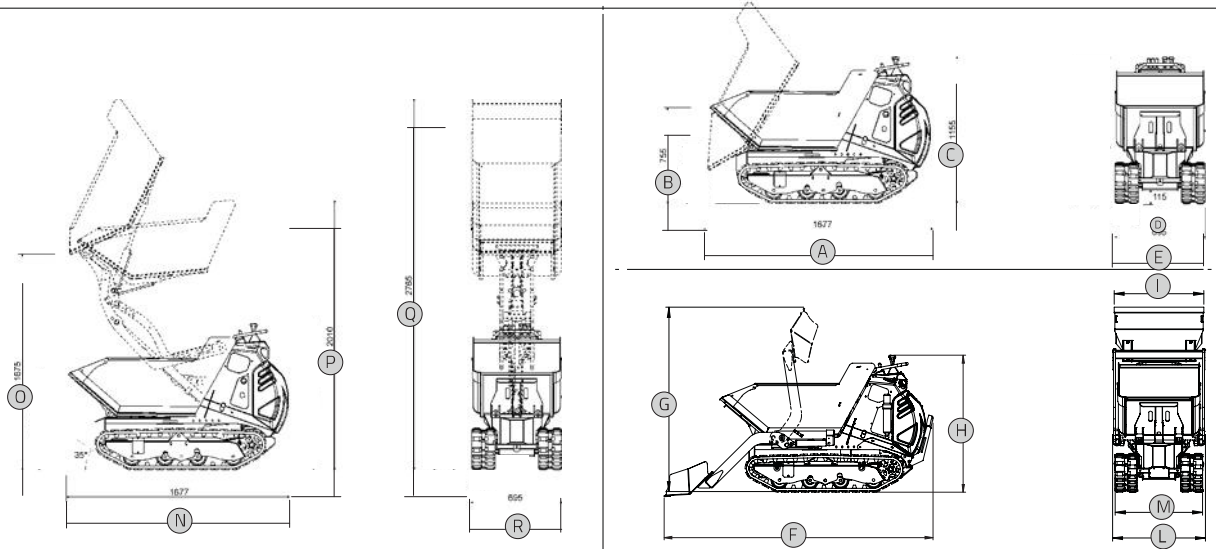

CAPACITA' CASSONI

BE-DE-BHE DHE-ACDHE-DEAC	ACQUA 0,15 m ³ 0,2 yd ³	RASO 0,22 m ³ 0,29 yd ³	COLMO SAE 0,28 m ³ 0,37 yd ³
RIA		RASO 0,13 m ³ 0,17 yd ³	COLMO SAE 0,21 m ³ 0,27 yd ³

DATI TECNICI

	METRIC	U.S.	6.60	9.60	
MOTORE					
Benzina	Honda GX 270 9 hp			●	
Diesel	Yanmar LA 70 7.5 hp		●		
TRASMISSIONE					
Tipo	Hydrostatic		●	●	
Pompa idraulica	n°3 Gear pump		●	●	
SOTTOCARRO					
Larghezza cingoli	180 mm	(7.1 in)	●	●	
Rulli oscillanti	Yes		●	●	
IMPIANTO IDRAULICO					
Pompa idraulica	Gear pump				
Flusso	1x16 l/min	(1x4.2 gpm)	●	●	
Pressione max	170 bar	(2466 psi)	●	●	
PRESTAZIONI E DIMENSIONI					
Velocità max	approx 0-3.6 Km/h		(0-2.3 mph)	●	●
Capacità operativa	600 kg		(1320 LB)	●	●
Pesi	BE 463 kg /1021 lb	BHE 552 kg /1217 lb	ACBE 506 kg /1116 lb	ACBHE 628 kg /1385 lb	●
	DE 476 kg /1049 lb	DHE 567 kg / 1250 Lb	DEAC 520 kg / 1146 Lb	ACDHE 638 kg / 1407 Lb	●
Capacità cassone	0,25 m ³ - 0,33 yd ³			●	●
Freno di stazionamento	Yes			●	●

