



Bobcat®

S100 Skid-Steer Loader



One Tough Animal™

Specifications

Performance

Rated Operating Capacity¹
Tipping Load
Hydraulic Pump Capacity
Travel Speed
Operating Weight

S100

1000 lb. (453 kg)
2039 lb. (925 kg)
13.1 gpm (49.6 L/min.)
6.5 mph (10.4 km/hr.)
4110 lb. (1864 kg)

Dimensions

Length (with bucket)
Width (with bucket)
Height
Height to Bucket Pin

110.2 in. (2800 mm)
50 in. (1270 mm)
73.9 in. (1878 mm)
103.6 in. (2633 mm)

Engine

Model
Fuel/Cooling
Cylinders
HP/Displacement
Fuel Tank Capacity

V1505
Diesel/Liquid
4
35.5/94.4 cu. in. (1498 cc)
11.9 gal. (45 L)

Operation

Steering and Drive

Forward, reverse, travel speed and steering controlled by two hand levers.

Hydraulics

Raise/lower lift arms and dump/rollback bucket controlled by two foot pedals.

Transmission

Hydrostatic, four-wheel drive.

Standard Features

| | |
|---|------------------------------|
| Adjustable Cushion Seat | Front & Rear Lights |
| Automatically Activated Glow Plugs | Lift Arm Support |
| Bobcat Interlock Control System (BICS™) | Meters/Gauges/Warning Lights |
| Bob-Tach™ | Parking Brake |
| Deluxe Cab | Seat Bar |
| Engine/Hydraulic Shutdown | Seat Belt |
| Front Auxiliary Hydraulics | Spark Arrestor Muffler |
| | 27x8.5-15 Heavy-Duty Tires |

Options/Accessories

| | |
|--------------------------------|---|
| Attachment Control Kit | Service Safety Training Course |
| Backup Alarm | Skid-Steer Loader Operator Training Kit |
| Cab Enclosure with Heater | Sound Cab (Reduces noise at operator's ear) |
| Catalytic Purifier | Special Applications Kit² |
| Flasher/Strobe Lights | Suspension Seat |
| Flotation Tire 27x10.5-15 Horn | |
| Hydraulic Bucket Positioning² | |

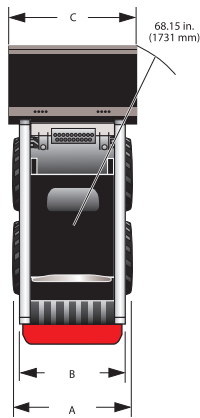
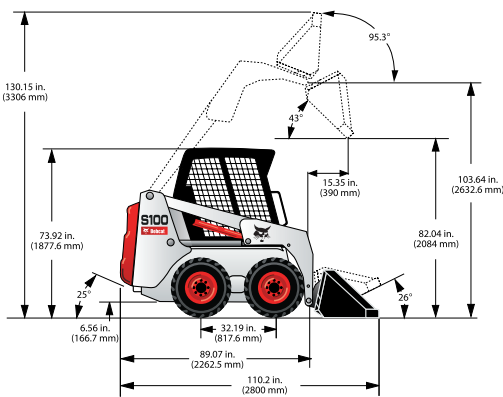

Lots of Skid-Steer Muscle in a Smaller Package!

Got to get the work done, but don't have much space to maneuver? Give the Bobcat® S100 skid-steer loader a try!

The S100 delivers 1,000 pounds of lift capacity, yet easily fits through narrow openings. It weighs only 4,110 pounds for easy trailering.

With a travel speed up to 6.5 mph, you'll get your longer-run jobs done faster. And this peppy S100 loader is also better balanced for greater work efficiency.

It features proven safety technology — the Bobcat Interlock Control System (BICS™). BICS requires the operator to be seated in the loader with the seat bar in place and the engine running. After the “press to operate loader” button is pushed, the hydraulic lift/tilt functions and traction-drive system can be operated.

Plus, with the S100 you get more than an exceptional skid-steer loader — you get unmatched support from a worldwide network of Bobcat dealers offering industry-leading attachments, accessories and parts availability. Their factory-trained service technicians are equipped to handle all your parts and service requirements, including engine and hydrostatic/hydraulic components. There's also an excellent warranty program.

See your Bobcat dealer for details.

The Bobcat S100 — it's the agile, reliable loader that can improve your tight-fit job efficiency!

1,000 LB.
Rated Operating Capacity
103.6 IN.
Lift Height
35.5 HP
Liquid-Cooled Diesel Engine

NOTE - Where applicable, dimensions are in accordance with Society of Automotive Engineers (SAE) and ISO standards. Specifications and design are subject to change without notice. Pictures of Bobcat skid-steer loaders may show other than standard equipment. All dimensions are shown in inches. Respective metric dimensions are enclosed by parentheses. Bobcat Company complies with the requirements of ISO 9001 as registered with BSI.

¹Operating capacity rated with standard digging bucket according to SAE standard J818 — OPERATING CAPACITY TO EQUAL NO MORE THAN ONE HALF THE TIPPING LOAD.

²Bucket positioning helps operator keep the same tilt of the load during lifting.

³Includes polycarbonate front door, top and rear windows.

- A. 27 x 10.50 – 15 Tires – 45.94 in. (1167 mm)
- B. 27 x 10.50 – 15 Tires – 38.07 in. (967 mm)
- C. Bucket Width – 50 in. (1270 mm)

Bobcat Attachments for this model:

- Angle Broom*
- Auger
- Backhoe
- Bale Fork
- Breaker
- Brush Saw
- Buckets
- Digger
- Dumping Hopper
- Grapple, Industrial
- Grapple, Root
- Grapple, Utility (for use with utility fork or bucket)
- Landplane
- Pallet Fork
- Scarifier
- Scraper
- Snow Blade
- Snowblower*
- Snow V-Blade*
- Soil Conditioner*
- Sweeper
- Three-Point Hitch
- Tiller
- Tree Fork
- Trencher
- Utility Fork